

Bowers & Wilkins

CWMM3

Welcome to Bowers & Wilkins and the CWM3 Series

Thank you for choosing Bowers & Wilkins. When John Bowers first established our company he did so in the belief that imaginative design, innovative engineering and advanced technology were keys that could unlock the enjoyment of audio in the home. His belief is one that we continue to share and it inspires every product we design.



1. Unpacking

CWM3 Series in-wall speakers are designed to offer easy installation and high quality audio reproduction for discrete custom install applications. They are particularly suitable for use in humid environments such as swimming pools. This manual describes the installation of CWM3 Series speakers within conventional stud and sheetrock (joist and plasterboard) walls. It begins by listing the contents of the carton:

1. Two CWM3 Series speakers
2. Two CWM3 Series speaker grilles
3. Two aperture templates
4. Two paint masks
5. Quick Start Guide
6. Warranty information

2. CWM3 Series Basics

CWM3 Series in-wall speakers comprise a baffle carrying the speaker drivers, crossover circuit and connectors, and a magnetically secured grille. The baffle is secured in the wall aperture by dog-clamps that swing outwards and tighten.

CWM3 Series in-wall speakers require wall aperture and minimum depth clearance as follows:

- Model** CWM362
- Aperture Height** 275mm (10.9 in)
- Aperture Width** 181mm (7.2 in)
- Minimum Depth Clearance** 76mm (3 in)

Note: If CWM3 Series speakers are to be installed in "new build" projects, pre-mount kits and back boxes are available. Use of pre-mount kits is described in Section 5. Use of back-boxes is described in the separate CI300 Back-box Installation document.

Before installing CWM3 Series speakers you should ensure that the wall locations chosen are free of obstructions such as pipe work, ducting or wiring that will interfere with the installation. In existing dry-wall construction, use a stud-finding tool to help you map the wall construction and a pipe detector to scan the proposed installation locations.

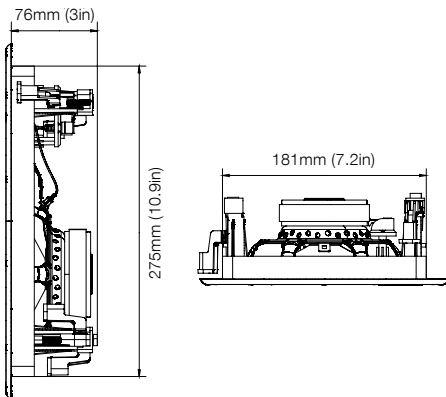

Diagram 1
Aperture and height clearance

3. Positioning CWM3 Series Speakers

The appropriate position for CWM3 Series speakers within the listening environment will depend on their specific application:

General Background Audio Applications:

For applications where single CWM3 Series speakers are required to operate independently to provide background audio, they can be located substantially as installation convenience and architecture dictate. The only acoustic constraint to bear in mind is that corner locations will result in significantly emphasised low frequencies and should be avoided.

Stereo Audio Applications:

For applications where a pair of CWM3 Series speakers is to be used for conventional stereo reproduction, they should be located between 3m (10 ft) and 5m (16.5ft) apart and a similar distance in front of the listening area. Try to avoid corner locations for the speakers and to ensure that acoustic environment around each speaker is similar.

Note: Different acoustic environments might be, for example, a bare wall and a heavily curtained window.

Multi-channel Audio Applications

For applications where multiple CWM3 Series speakers are to be used for multi-channel audio visual systems, the left and right front speakers should be located either side of the screen approximately 0.5m (20 in) away. The centre channel speaker should be located either directly above or below the screen or, in the case of an acoustically transparent screen, directly behind. Surround channel CWM3 Series speakers should be located just behind and either side of the listening position. Try to avoid corner locations for any of the speakers and to ensure that the acoustic environment around each front and surround speaker is similar.

Note: Different acoustic environments might be, for example, a bare wall and a heavily curtained window.

Diagram 2 illustrates the general speaker location guidelines.

Note: The nature of the installation of in-wall speakers means that it is sometimes impractical to locate them in the acoustically ideal positions. In these cases they should be located as close as is practical to the ideal positions. Your local Bowers & Wilkins retailer will be able to offer advice if required.

Note: CWM3 Series drive units create stray magnetic fields. We recommend that magnetically sensitive items such as CRT screens and magnetic cards for example, are kept at least 0.5m (20 in) from the speaker. LCD and plasma screens are not affected by magnetic fields.

Stereo Audio Applications

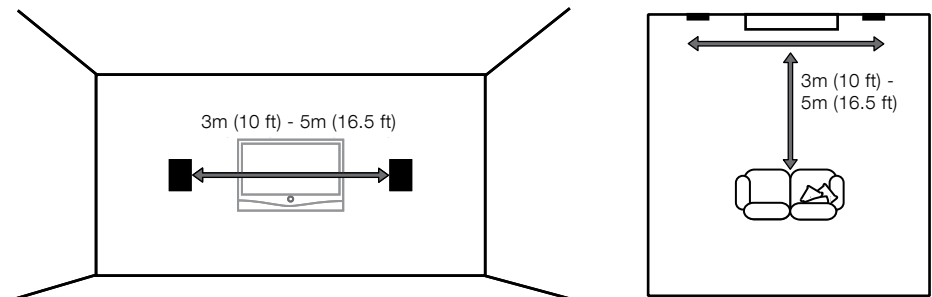

Multi-channel Audio Applications

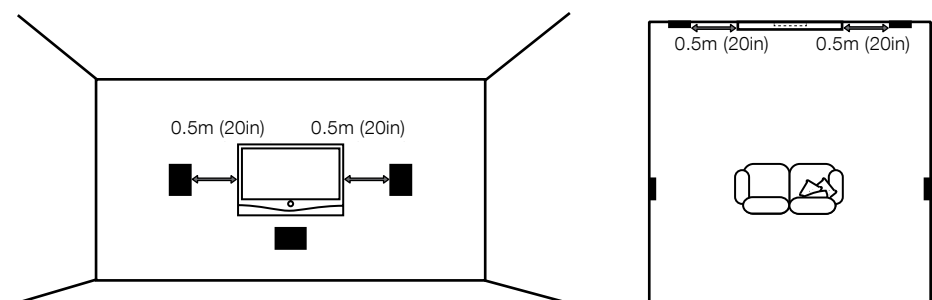

Diagram 2
Positioning

4. Installing CWM3 Series Speakers

To install a CWM3 Series speaker, proceed as described in the following paragraphs:

4.1 Using the supplied aperture template, mark a cut line on the wall. Check the cut line defines the correct aperture dimensions. Cut along the line with an appropriate tool to create a rectangular aperture in the wall.

Note: Ensure that there is enough free space internally adjacent to the aperture for the dog clamps.

Note: To reduce the possibility of the wall buzzing or rattling, adhesive mastic can be applied between the studs and sheetrock in the vicinity of the speaker aperture.

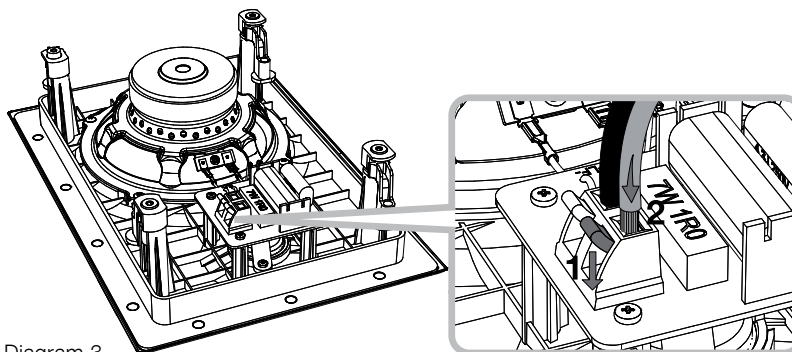
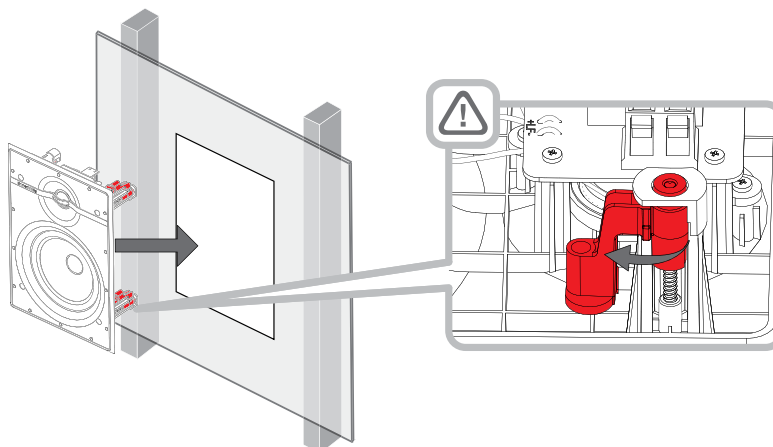

Diagram 3
Cable connection

4.2 If speaker cable is already present in the wall, feed the cable through the aperture. If speaker cables are not already installed, this should be done at this stage. It is likely that you will need to gain access through the floor above to route the cables down through the wall space.

Leave enough spare cable through the aperture to ease connection to the speaker, but not so much that it is likely to buzz or rattle when pushed back into the wall space. Approximately 1.0m (3 ft) is appropriate.

Note: Always use high quality, low resistance speaker cable. Low resistance is especially important if the length of cable from amplifier to speaker exceeds 5m. Your local Bowers & Wilkins retailer will be able to offer advice on speaker cable selection if required.



4.3 Now connect the speaker cable to the spring terminals on the crossover board. Ensure that the speaker connection polarity is correct: the cable connected to the positive terminal on the amplifier should be connected to the red spring terminal on the speaker. Similarly, the cable connected to the negative terminal on the amplifier should be connected to the black spring terminal on the speaker. Diagram 3 illustrates cable connection.

Note: If an amplifier is already connected to the cable it should be switched off while connections are being made to the back box.

4.4 With the speaker connected to the cable, it can be inserted into the wall aperture. Ensure that the four dog clamps are rotated inwards so that they can pass through the aperture, and then hold the speaker flange flush to the wall. Take care that the connection cable does not become trapped anywhere.

Diagram 4
Secure the speaker

To secure the speaker use a Phillips screwdriver inserted through the dog-clamp access holes in the front of the speaker. Take great care not to damage the speaker drive units with the screwdriver. Engage the screwdriver with each dog-clamp screw in turn and tighten them. Diagram 4 illustrates inserting and securing the speaker.

Note: If the wall is to be painted after the speakers have been installed, the supplied paint mask should be used.

4.5 The grille can now be fitted. The grille is held in place magnetically so simply needs to be aligned with the groove in the frame flange where it will click into place. Diagram 5 illustrates fitting the grille.

The CWM3 Series speaker is now installed and ready for use.

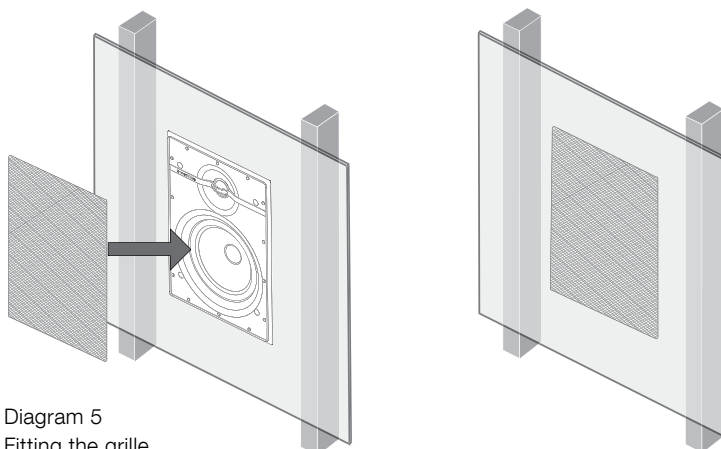

Diagram 5
Fitting the grille

5. Using a Pre-mount Kit

Custom install pre-mount kits enable the locations of in-ceiling and in-wall speakers to be defined before the sheetrock (plasterboard) is fitted to the studs (joists). Routing and cutting of speaker cable is also made easier using pre-mount kits. A pre-mount kit (PMK) comprises a plastic moulding that defines the aperture size of the specific speaker model, two perforated metal straps and four plastic clips.

To use a PMK, first attach one strap to each side of the moulding using the plastic clips. The PMK assembly can now be attached to the studwork by nailing the metal straps to the studs so that the plastic moulding is located at the appropriate position.

When the sheetrock (plasterboard) is subsequently fitted (marked on the outside to denote the position of the pre-mount kit) the PMK plastic moulding serves as an internal cut guide that significantly eases cutting the speaker aperture.

Diagrams 6-9 illustrate PMK installation.

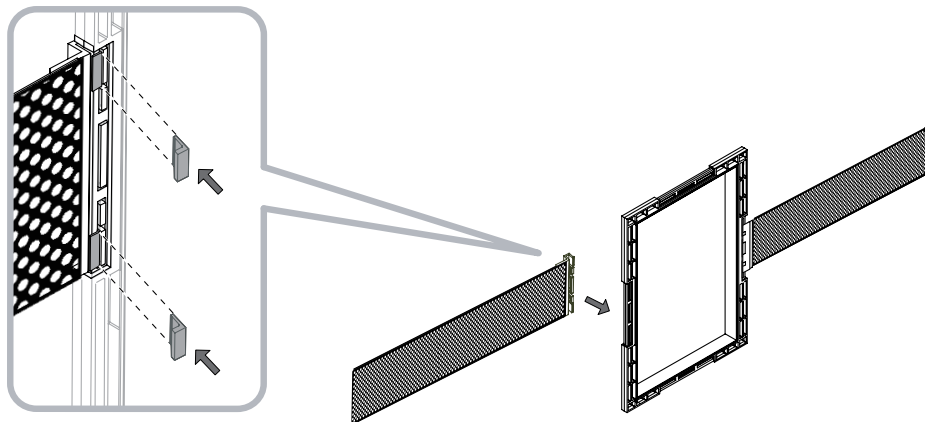

Diagram 6
PMK strap attachment

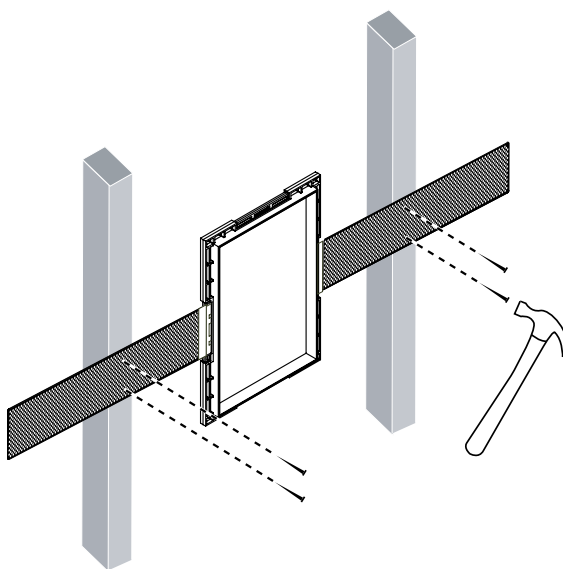
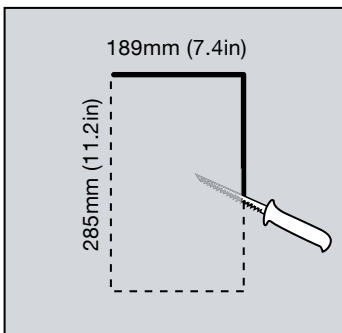

Diagram 7
PMK stud (joist) installation

PMK W6



PMK W5

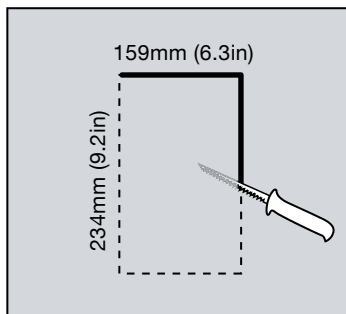

Diagram 8
PMK cutout dimensions

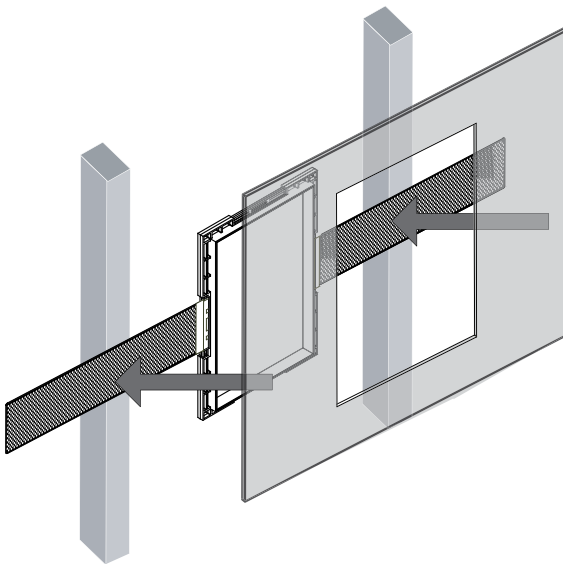

Diagram 9
Sheetrock (plasterboard) installation

6. Using a Back-box Kit

Custom install back-box kits comprise a fire-proof box that can be fitted behind in-wall or ceiling speakers before the sheetrock (plasterboard) is fitted to the studs (joists). As well as enabling compliance with fire regulations, back-boxes also help optimise speaker performance by providing a defined acoustic loading volume. A minimum clearance depth of 90mm from the outer stud (joist) plane to any rear obstruction is required to fit a back-box.

Back-boxes incorporate holed side flanges that are intended to be nailed to adjoining studs (joists). All the nail holes should be used to help minimise the risk of the flange vibrating against the stud (joist) when the speaker is in use.

Speaker cable is brought into back-boxes via sealing glands. Once the cable has been brought through the gland, and the gland tightened, fire-retardant sealing mastic should be used to seal the assembly. Ensure that a generous length of cable is available in the back-box before the gland is sealed. A cable clamp adjacent to the gland provides cable strain relief.

When the sheetrock (plasterboard) is fitted over the back box a generous bead of fire-retardant sealing mastic should be applied to the back box flanges in order to seal the assembly and minimise the possibility of vibration when the speaker is in use.

Diagrams 10-12 illustrate back-box installation.

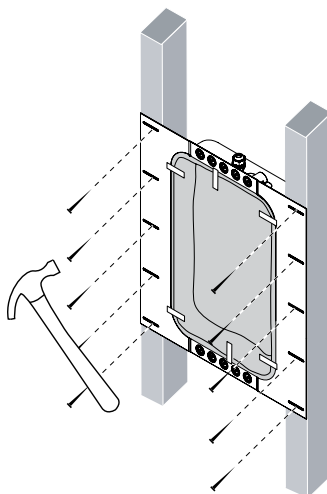

Diagram 10
Back-box stud (joists) installation

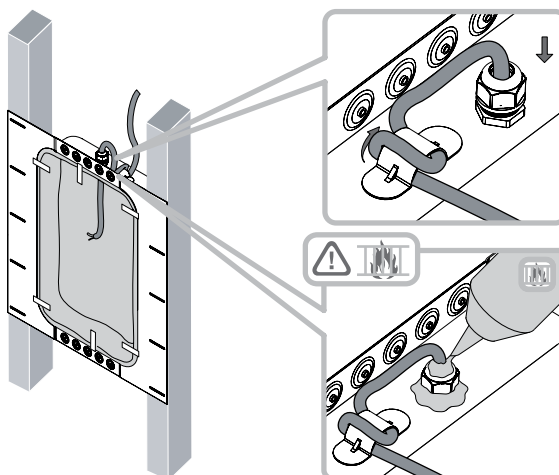

Diagram 11
Cable installation

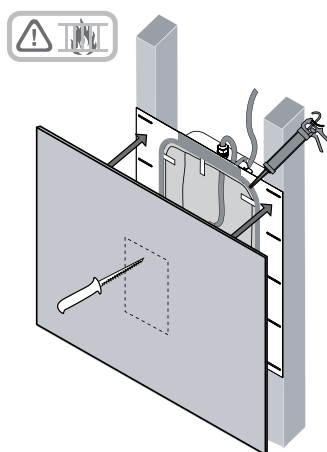

Diagram 12
Sheetrock (plasterboard) installation